

FEEDER-FE2000

Fabric Feeder Machine

- The Feed-Batch are units developed for the inkjet fabric printing machines.
- Designed to provide continuous fabric supply and take off to any type of inkjet printer available on the market.
- The unit automatically feeds fabric from roll into an inkjet printer and is automatically winding the printed fabric into a roll.

FABRIC FEEDER

- Fabric unwinding device with fabric tension roller.
- Fabric joining bar with needle holder.
- Full width scroll roller.
- One side automatic edge control.
- The entire unit is mounted on swivel wheels.

FABRIC WINDING:

- Fabric winding device with tension/dancing bar.
- fabric detection photocell.
- The entire unit is mounted on swivel wheels.

OPTIONAL FEATURES

- Set recommended spare parts.
- On site installation and training.

FEEDER-FE2000



FEEDER-FE2000



ПЯТЫЙ ПАРТНЕР



rimslow global Pty Ltd

Diagram Drawing

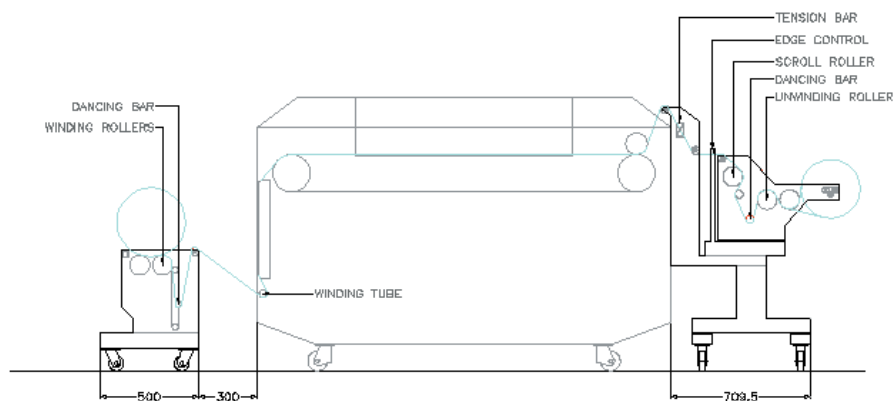

Rimslow Global Pty Ltd. Prohibit to totally or Partially copy this drawing or to divulge it without expressing previous authorization. Rimslow Global Pty Ltd reserves the right to legally pursue any transgressors

FEEDER-FE2000

	Units	
Fabric Maximum width	mm	1850
Maximum Speed	m/hr	60 (linear meters)
Machine Length	m	2.3
Machine Width	m	0.6
Machine Height	m	1.3
Power Consumption	kW	1.0
Fabric Roll Diameter	mm	250
Power Supply	-	220/240V, 50-60Hz 6A



Страница
FEEDER-FE2000